



Wi-iQ[®]

BATTERY MONITORING DEVICE



WI-IQ®4 BATTERY MONITORING DEVICE OWNER'S MANUAL

TABLE OF CONTENTS

1. Features.....	3
2. Technical Specifications.....	3
3. Dimensions	5
4. Installation.....	5
5. Communication	6
6. Service and Troubleshooting.....	9

1. FEATURES

The Wi-iQ®4 battery monitoring device is the fourth generation of battery sensor technology, providing incremental features such as Bluetooth and CAN-Bus connectivity to improve communication and integration with other devices and external equipment. Features added to the new compact design include three LEDs to communicate status, a new LCD display to show important battery information and an audible alarm.

- Programmable
- Wi-iQ4 device can be assembled on batteries from 24V to 80V
- Small and slim fit
- IP65 enclosure
- Available for flooded lead acid and NexSys® TPPL battery chemistries
- Single or dual cable current sensors
- LCD display and low voltage alarm buzzer
- Memory capable of more than 8,000 events
- Multiple communication channels
 - Zigbee® wireless to Wi-iQ Report PC software and charger
 - Bluetooth to E Connect™ mobile app and Truck IQ™ smart battery dashboard
- Newly designed E Connect mobile app enables fast and easy check-up of battery fleet and data sharing
- Connection with our external Truck iQ device that shows real time data to operator about battery status, alarms and remaining working time
- Optional CAN-Bus module provides State of Charge (SOC) and other data to any CAN network (e.g. lift trucks, AGVs)
- Compatible with Xinx™ warehouse management efficiency system to simplify both data collection and reporting
- Wireless communication with EneSys® modular charger allows for better asset control
- Adjustable SOC Warning and provides an audible alarm
- Eliminates need for separate Low Voltage Alarm (LVA) device

NOTE: The Wi-iQ4 device is designed to install only on a battery and will not function properly if mounted on the truck side of battery connector for a power study.

2. TECHNICAL SPECIFICATIONS

Item	Description
Nominal Battery Voltage	24VDC to 80VDC
Operating Voltage	15V-120V
Operating Temperature	4°F (-20°C) – 140°F (60°C)
Bi-directional Current Measurement	Allows for throughput data collection using a Hall effect sensor which can measure up to +/- 1000A. 1A resolution
Voltage Measurement	Continuous monitoring of overall battery voltage and half battery voltage
Voltage Accuracy	0.1V
Temperature	External thermistor
Altitude	<2,000m (<6,561ft)
Electrolyte Level Detection	With electrolyte sensor
Wireless Interface	Zigbee (SMAC -2.4Ghz), Bluetooth BLE
Real Time Clock	Time keeping and stamping of data
Data Storage	Upload data to PC via Dongle, to Cloud server via E Connect mobile app
Data Collection	Up to 8,000 event log records
Wireless Range	Up to 10m (32ft) (Zigbee); up to 5m (16ft) (BLE)
CAN Communication	2 different CAN protocols: CANOpen or J1939
Power Consumption	1 Watt
Protection	Over voltage Reverse Polarity Protection Water and acid resistant
Packaging	UL 94V-0 Pollution level 3 protection (dusty environment) IP65 enclosure
Physical Dimensions	40,07mm L x 19,5 mm W x 107,97mm H
Compliance	Electrical Equipment (Safety) Regulations 2016 (S.I. 2016/1101) Directive 2014/35/EU : Safety BS EN 61010-1 : 2010 / A1 : 2019 EMC Regulations 2016 (S.I.2016/1091) Directive 2014/30/EU : Electromagnetic compatibility BS EN 12895 : 2015 / A1 : 2019 Directive 2011/65/EU RoHS Radio Equipment Regulations 2017 (S.I.2017/1206) Directive 2014/53/EU ETSI EN 301 489-1 V2.2.3 (2019) ETSI EN 301 489-17 V3.2.2 (2019) ETSI EN 300 328 V2.2.2 (2019)

THIS DEVICE COMPLIES WITH PART 15 OF THE FCC RULES. OPERATION IS SUBJECT TO THE FOLLOWING TWO CONDITIONS:

- (1) THIS DEVICE MAY NOT CAUSE HARMFUL INTERFERENCE
- (2) THIS DEVICE MUST ACCEPT ANY INTERFERENCE RECEIVED, INCLUDING INTERFERENCE THAT MAY CAUSE UNDESIRE OPERATION.

IN ACCORDANCE WITH FCC REQUIREMENTS, CHANGES OR MODIFICATIONS NOT EXPRESSLY APPROVED BY ENERSYS COULD VOID THE USER'S AUTHORITY TO OPERATE THIS PRODUCT.

Technical support: Reference www.enersys.com to find your local contact.

2.1 Components

Figure 1: Wi-iQ4 Device for Flooded Batteries with Electrolyte Probe



2. TECHNICAL SPECIFICATIONS (CONTINUED)

2.2 The Wi-iQ[®]4 Battery Monitoring Device

2.2.1 The Wi-iQ[®]4 battery monitoring device consists of:

- A main unit (for voltage measurement, display, LEDs, buzzer and communication features)
- 1 or 2 current sensors
- A CAN connection (Use is optional)
- Red/Black cables to power the Wi-iQ4 device
- Balance/Gray wire for mid battery voltage
- Temperature probe
- Electrolyte level probe for flooded battery version
- 3 crimping splices + 3 cable ties
- Installation hardware

Figure 2: Wi-iQ4 Device for Thin Plate Pure Lead (TPPL) or Valve Regulated Lead Acid (VRLA) with CAN Connector; without Electrolyte Probe

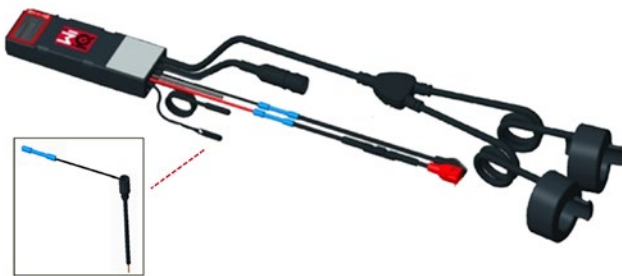

2.3 The Wi-iQ4 Device Part Numbers

2.3.1 There are four part numbers available.

Table 1: Part Numbers

Part Number	Reference P/N	Description	Battery Type
WIIQ4	6LA20743-E0E	Wi-iQ4 monitor Basic flooded single sensor	Flooded
WIIQ4DUAL	6LA20743-E3E	Wi-iQ4 monitor Basic VRLA single sensor	Gel, TPPL
WIIQ4F	6LA20743-E1E	Wi-iQ4 monitor Premium CAN single sensor	All with CAN
WIIQ4DUALF	6LA20743-E2E	Wi-iQ4 monitor Premium CAN dual sensor	All with CAN
6LA20761	6LA20761	Electrolyte sensor (replacement part only) do not use this number when ordering part number WIIQ4 and WIIQ4DUAL	Flooded

2.4 The Wi-iQ4 Device Display and LEDs

2.4.1 An LCD display and three LEDs on the Wi-iQ4 device provides status indication. The display is turned OFF after 15 minutes of no activity (sleep mode). A small touch to the Wi-iQ4 display will turn the display back ON.

Figure 3: Display and LEDs



2.4.2 Parameters displayed.

Table 2: Parameters

Description	Value	Comment
SOC	0-100%	State of Charge of the battery
Battery Voltage	Ex: 27.2V	Overall battery voltage (V)
Temperature	Ex: 64°F (18°C)	Battery Temperature
Current	Ex: 10.4A	Current value in A (+ charge, - discharge)
Bluetooth Connected		When the smartphone is connected to the Wi-iQ4 device
	Level	Blue LED ON
	Temperature	Red LED Flashing or ON
	Low SOC Warning	Buzzer ON
	Low SOC Alert	
Warning	Unbalance	Blue LED flashing
	No Current Sensor	CURRENT/SENSOR NO/SIGNAL
	No Temperature Sensor	TEMP/SENSOR NO/SIGNAL

2.4.3 LED Colors and Functions

Table 3: Colors and Functions

LED	Color	Lit	Fast blinking (0.5s ON / 0.5s OFF)
Left	Red	High Temperature	Warning Temperature
Center	Orange	Alert DOD	Warning DOD
Right	Blue	Low level	Unbalance
All		Fast blink every 5 seconds (for normal operation)	

NOTE: When the Wi-iQ4 device is first connected to the battery voltage, all LEDs are flashing and Firmware revision is shown on the display (initialization sequence). The SOC shown will be a reloaded value from the manufacturer. To start, please set the device and reset the value (refer to the configuration section of the manual).

2.5 Buzzer

2.5.1 There is a buzzer located inside the main unit. The buzzer is activated when the SOC of the battery is low and the battery needs to be charged. Reference Table 5.

Table 4: Warning and Alert Time Frequency

	Normal SOC	Warning SOC	Alert SOC
Buzzer	OFF	2 chirps every 20 seconds	1 chirp every 5 seconds

Table 5: Default value of the buzzer vs. battery type

Battery Type*	Warning SOC	Alert SOC
NexSys TPPL NXS models	30%	20%
NexSys TPPL NXP models	50%	40%
Others	30%	20%

*Adjustable

2.6 The Wi-iQ4 Device Current Sensor(s)

2.6.1 The current sensor is a solid core hall effect device.

Table 6: Current Sensor Technical Specification

DC Cable Gauge*	AWG	Internal Diameter	Truck Class Recommendation	Max DC Current
Up to 120mm ²	Up to 4/0	20.1 mm	Class 1, 2 & 3	1000A

NOTE: The DC cable gauge does not consider the terminal lug or contact dimensions. Terminal lugs or contacts may need to be assembled after inserting the cable in the current sensor. Mostly for the 4/0 cables.

2. TECHNICAL SPECIFICATIONS (CONTINUED)

2.7 Wi-iQ4 Device CAN option

2.7.1 If equipped, the Wi-iQ4 device communicates via CAN protocol.

2.7.2 The Wi-iQ4 device main unit is delivered with a protective plastic cap that needs to be removed to use the CAN option.

2.7.2.1 The female connector pinout is described below.

Figure 4: Female Connector

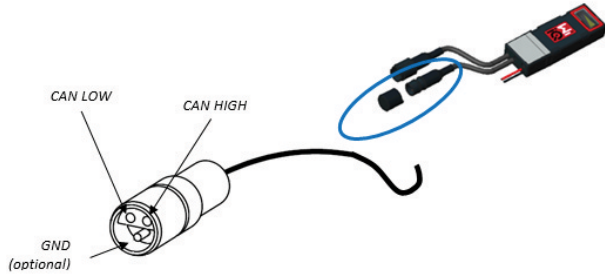

2.7.2.2 Male connector is NOT included (ITT-CANON SURE-SEAL IP68 3-contact receptacle with two pins and one socket adapted for 0.75-1.5mm² wires).

Table 7: CAN Connector Specification

Product	Receptacle Part Number	Wire Gauge	Contact Part Number	
			Pin (qty 2)	Socket (qty 1)
ITT-CANON SURE-SEAL	120-8551-001 (SS3R)	0.5–1.0mm ²	330-8672-001 (SS20)	031-8703-001 (SS20)
		0.75–1.5mm ²	330-8672-000 (SS10)	031-8703-000 (SS10)

2.7.3 The Wi-iQ4 device CAN communication adopts two different CAN protocols:

2.7.3.1 CANOpen

2.7.3.2 J1939

2.7.4 Refer to section 5.7 for proper documentation.

3. DIMENSIONS

3.1 Wi-iQ4 Device and Hall effects overall dimensions (mm)

Figure 5: Dimensions

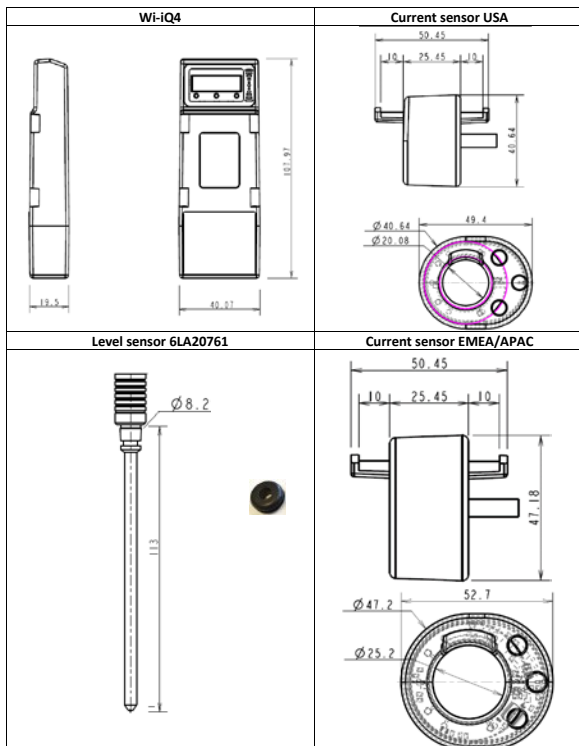

NB: All dimensions are given in mm.

Figure 6: Probes and Sensors

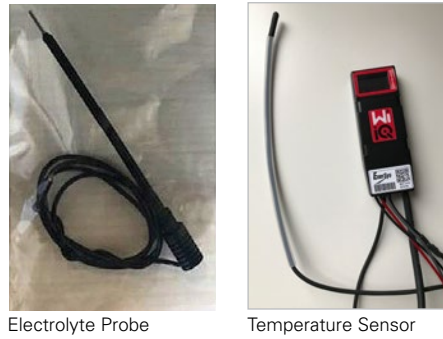

4. INSTALLATION

Figure 7: Wi-iQ4 Device Final Assembly on 2V Cell Tray

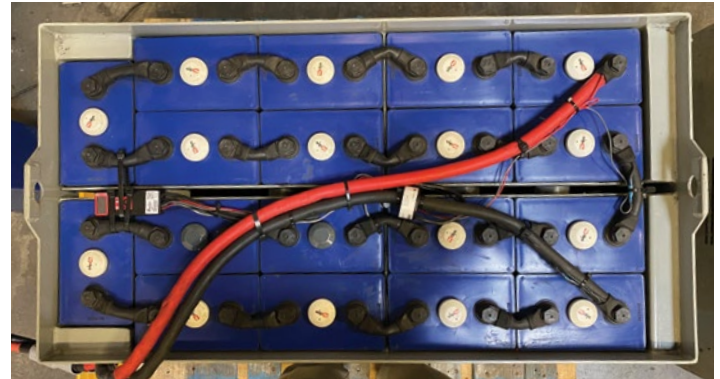
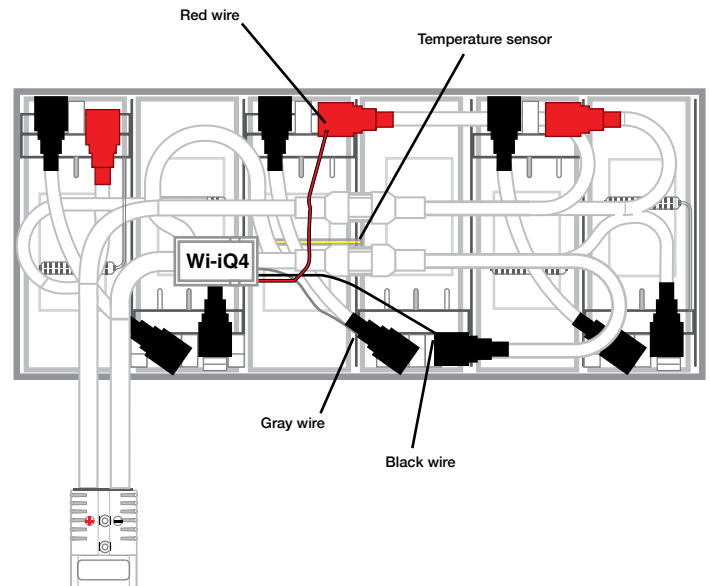

Figure 8: Wi-iQ4 Device Final Assembly on 12V Block Tray



NOTE: The stack order on the stud is: Battery Cable, Wi-iQ4 Device Ring Terminal, Flat Washer, Lock Washer and Nut.

- 4.1.1.1** Ensure the threads on the nut and stud are clean, place a drop of blue Loctite™ on the stud and tighten the nut in place.
- 4.1.1.2** Torque the nut to the proper specification (above). Ensure the battery cable lug is flat against the plate.

5. COMMUNICATION

There are two modes of communication (Wireless and CAN) available on the Wi-iQ⁴ device:

5.1 Wireless

5.1.1 BLE

- 5.1.1.1 Connect to a smartphone via E Connect mobile app
- 5.1.1.2 Connect to Truck iQTM smart battery dashboard

5.1.2 Zigbee[®] (legacy protocol in use with previous generations of Wi-iQ device)

- 5.1.2.1 Connect to chargers (NexSys[®]+ battery charger)
- 5.1.2.2 Connect to Wi-iQ Report software
- 5.1.2.3 Connect to XinxTM software

5.2 The Wi-iQ4 device can be configured and provide data via Zigbee[®] (Wi-iQ Report – v5.4.5 minimum) or BLE (E Connect app – v2.16 minimum).

5.3 CAN (Controller Area Network)

5.3.1 CANOpen Cia 418 or J1939

- 5.3.1.1 Interface with truck using an Original Equipment Manufacturer (OEM) proprietary CAN protocol implemented.
- 5.3.1.2 Interface with AGV using EnerSys proprietary CAN protocol.

5.4 Configuring Wi-iQ4 Device within Wi-iQ Reporting Suite

- 5.4.1 Once the device is installed, it must be set-up in the software. Plug a dongle (Wi-iQ antenna) into the USB port of a PC with the Wi-iQ Reporting Suite installed. Start Wi-iQ Report software.
- 5.4.2 Click on the Software menu item in the upper left corner; click “Language” and select “US” (not English). This is necessary to ensure all the battery technologies (Bat. Techno) are available later in the software setup.
- 5.4.3 Create a new site if one does not already exist. The naming of the site is not important for installation purposes.

Figure 9: Wi-iQ Report Website Configuration Page

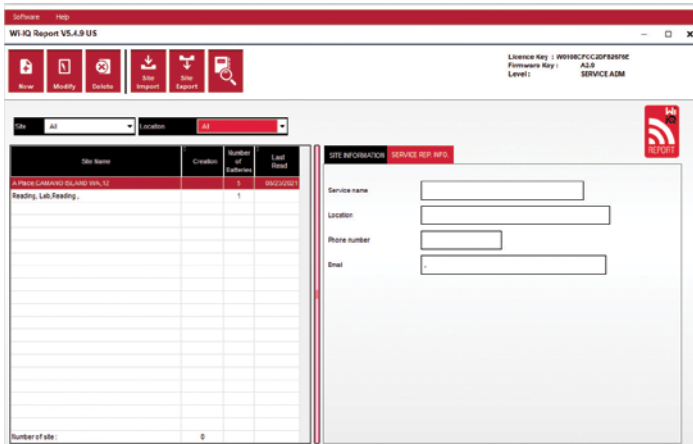

- 5.4.4 Double-click on the Site Name to open it. Previously added devices may be shown. To add a new device, click on the scan button at the top left. The software will scan for all available devices. Check the “Add” box for all devices you wish to configure and hit the “+ Add” button on the right. The devices can be identified by matching the Address (HEX) field to the S/N on the device.

Figure 10: HEX Address Match

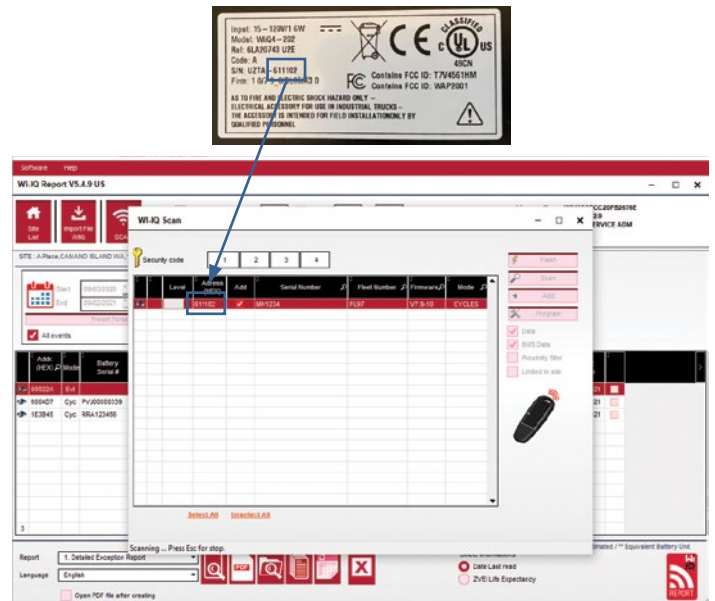

- 5.4.5 The devices you have added should now be added to the site view. If you have added multiple devices at once and you are unsure which device is on each battery, click on the eye icon in the left column. This will make all the LEDs on that device blink for 15 seconds. The device will also beep during the same period. Double click anywhere along the line of the device you wish to configure to open the configuration window.
- 5.4.6 ****If at any time the Laptop version will not pick up the Wi-iQ⁴ device or find correct serial number of device, configure correctly through Econnect app on appropriate serial number, scan again and it will now show up in your Wi-iQ Suite on your laptop.**

Figure 11: Wi-iQ4 Report Website Homepage

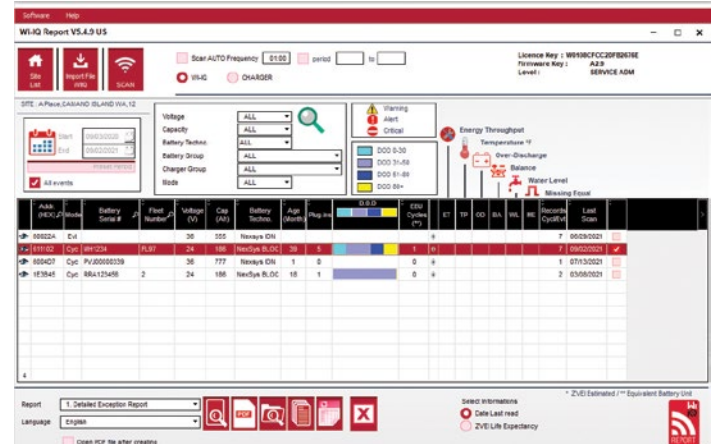

5. COMMUNICATION (CONTINUED)

Figure 12: Wi-iQ®4 Report Website Device Configuration Page

5.4.8 Battery SN# – Enter the battery serial number (9 digits).

5.4.9 Fleet number – As required

5.4.10 Model – Enter the battery type, ex: 18-E100-21

5.4.11 Cells – Enter the number of cells on the battery

5.4.11.1 For NexSys® TPPL 2V batteries, use total voltage divided by 2 to determine number of cells. Example – The battery type is 36NXS700. 36 describes the total voltage of the battery. Take this number and divide by 2 to get “Cells”; in this example, $36 / 2 = 18$ cells.

5.4.12 Cells Bal. – Enter the cell number where the gray wire was installed, counting from the positive post.

5.4.12.1 For NexSys TPPL Bloc Battery: The black Wi-iQ4 device wire and the gray Wi-iQ4 device wire should be attached to the negative and positive posts of the same bloc as described in section 4.1.13. In this configuration “Cells Bal.” will always be 6.

5.4.13 Battery Technology – Select the appropriate type of battery. Refer to line-item notes on BaaN order requesting any specific Battery Technology setting by customer or sales representative. If nothing is requested in the line item notes, refer to Table 8.

Table 8: Charge Profiles

Battery Technology	Battery Types
COLD STORAGE	All Flooded with average battery temperature below 59°F (15°C)
FAST US	85P(FC), 125P(FC), E100X, E140X
HG FLOODED*	E55L, E75L, E110, E155
LOW MAIN*	Deserthog (E90D, E100D, E125D)
NexSys 2V	NexSys TPPL 2V (NXS)
NexSys BLOC	NexSys TPPL Bloc (NXS)
NexSys TPPL 2V	Not used in North America
NexSys TPPL Bloc	NexSys TPPL Bloc (NXP)
OP CHARGE	All Flooded
STD FLOODED	All Flooded

***NOTE: The charge profile will be STD FLOODED when HG FLOODED, or LOW MAIN are selected. The purpose of selecting HG FLOODED, or LOW MAIN is to inform the Data Analyst of the specific type of battery being reviewed.**

5.4.14 Capacity (Ah) – Enter the nominal Ah of the battery.

5.4.14.1 NexSys TPPL Bloc Battery: Determine total battery Ah. Example: 24-12NXS186-3. 186 describes the amp hour rating of each block and 3 describes the number of parallel strings. Multiply these two numbers to get “Capacity (Ah)”; in this example $186 \times 3 = 558$ Ahrs.

5.4.14.2 NexSys TPPL 2V Battery: Determine total battery Ah. Example: 18-NXS770. The 770 describes amp hour rating.

5.4.15 (+) cable/(-) cable – Select the cable the Wi-iQ4 device has been installed on. In most cases, (-) cable should be selected.

5.4.16 Equal. Period (hours) – Enter 186. This is the time in hours to request equalization charge (only available with Wi-iQ4 device firmware v4.0 and higher). If equal time is set to 0 hours, this disables the feature and critical faults are not recorded on reports. This feature is not programmable for NexSys battery profiles.

5.4.17 Balance – Check this box for all batteries.

5.4.18 Water Level Probe – Check this box for all batteries with an electrolyte probe installed.

5.4.19 Mode – Leave as default – CYCLES, unless line-item notes on Order Acknowledgement requires an alternative mode setting by customer or sales representative. Note: Click on the “WRITE IDCARD” button prior to changing the mode. If mode is changed first, then restart configuration from step 5.6.1.

5.4.19.1 Xinx™ Systems require the Mode to be EVENT.

5.4.20 Dates – Enter the date from the battery date code for the “Date Manuf. Bat.” Field. Enter the date the battery is placed in service for the “Date Inst. serv.” field. Leave all other date fields blank.

5.4.21 Owner – Leave as default – ENERSYS.

5.4.22 Battery Group – Enter truck type – Sit Down, Reach, etc., or as designated by customer.

5.4.22.1 For Xinx, refer to the Xinx set-up worksheet.

5.4.23 Charger Group – Charger Model or Charger Max Output

5.4.24 Summertime Setting: OFF/Europe/Australia.

5.4.25 Once you have entered all of the required information, click on the “WRITE IDCARD” button. Select the “Write” button and confirm settings are written.

5.4.26 Click on the “CYCLES” tab. Find the button called “Reset Cycles” and click on it, select “Continue” when the warning message appears. This will erase any memory in the device. Installation is now complete. It is important to reset the data on a new installation for proper averaging calculations.

5.4.26.1 “Reset Events” for Xinx or any setup requiring EVENT Mode.

Figure 13: Reset Cycle Button

5.4.27 Xinx™ System Setup

5.4.27.1 Change mode to EVENT

5.4.27.2 The Battery Group must be set for the correct Pool Name in accordance with the note on the order and/or the Xinx BOM profile; e.g. Dock Stockers, Pallet Jack, etc. If you use all capital letters for one pool, make sure all the pools are named using all caps. This will be provided via a custom note on the order and/or the Xinx BOM profile. Any typo may result in the Xinx system failing to recognize the battery.

5.4.28 Use the “MEASURES” tab to verify setup

5.4.28.1 Select the “MEASURES” button to read Wi-iQ4 device real-time data

5.4.28.1.1 Measure voltage from the positive terminal of the battery to the VBAL/CEL gray wire with a calibrated voltmeter. Divide the reading by the number of cells between the positive terminal and the balance wire. Compare this value to the “VBAL/CEL” reading and confirm it is within a tolerance of (+/-) .02 VDC. Deviation from this value indicates the wrong number of cells was input into the “Cells Bal” field, or the Balance Wire is in the wrong location.

5. COMMUNICATION (CONTINUED)

- 5.4.38.1.2** Measure the voltage between the positive and negative battery post with a calibrated voltmeter. Divide the number of cells in the battery and confirm this value is within a tolerance of (+/- .03 VDC) of the value in "VBAT/CEL". Deviation from this value may indicate a bad electrical connection. Clean and grease the battery post and terminal lug.
- 5.4.28.1.3** Measure the temperature near the Temperature Probe on the battery. Verify the value in the "Temp" field is near the as read value. Large deviations indicate a bad thermal sensor.
- 5.4.28.1.4** If possible, operate the equipment or charge the battery. Measure the current with a calibrated clamp-on ammeter and confirm the value is within (+/- 2%) tolerance of the value in "CURRENT". Deviation from this value indicates a bad Hall Effect Sensor.
- 5.4.28.1.4.1** Also verify the current is in the proper direction, (-) for discharger and (+) for charge. Deviation from this indicates the Hall Effect Sensor was installed backwards.
- 5.4.28.1.5** Verify the electrolyte indicates properly. If the probe is covered and the indication in "Measures" is not green, verify the balance wire is on the negative post of the same cell the electrolyte probe is installed.

Figure 14: Live Readings on Wi-iQ4 Report

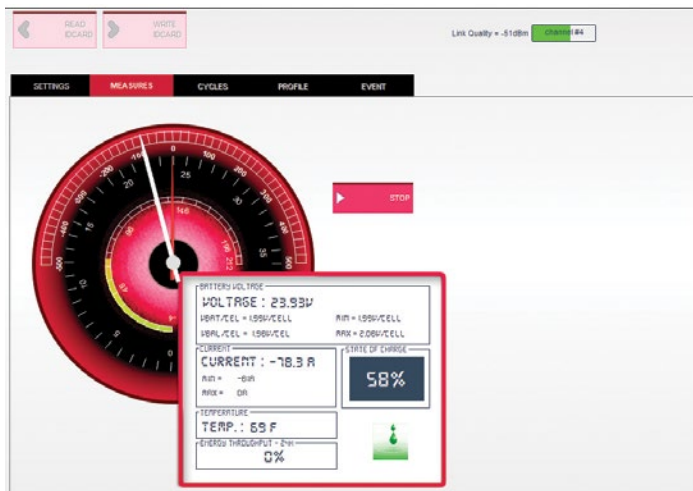

5.5 Configuring Wi-iQ4 device within the E Connect™ mobile app

- 5.5.1** A mobile app called "E Connect" is developed for iOS® and Android® operating systems (will not work on Windows platforms), available for download for free from App Store and Play Store. Access is protected by login/password. Different access levels will be granted through different access codes.
- 5.5.2** The E Connect mobile app allows mainly:
- 5.5.2.1** Scanning and then associate the Wi-iQ4 device to a customer site (list of devices will be automatically recorded on a remote server).
- 5.5.2.2** Setting the Wi-iQ4 device battery parameters (such as technology, capacity...).
- 5.5.2.3** Quick review of historical parameters such as SOC, voltage and temperature.
- 5.5.2.4** Downloading the Wi-iQ4 device history data (data downloaded are automatically transferred to a remote server* - there is no data stored on the Smartphone).

Notes:

- (1) When launching the mobile app, Bluetooth is automatically activated.
- (2) If the Smartphone is not connected to Internet during scan and data download, the transfer to the remote server will be done as soon as the Internet connection is restored.

- 5.5.3** The main screens of the E Connect mobile app with the main parameters are shown below.

Figure 15: E Connect Mobile App Screens

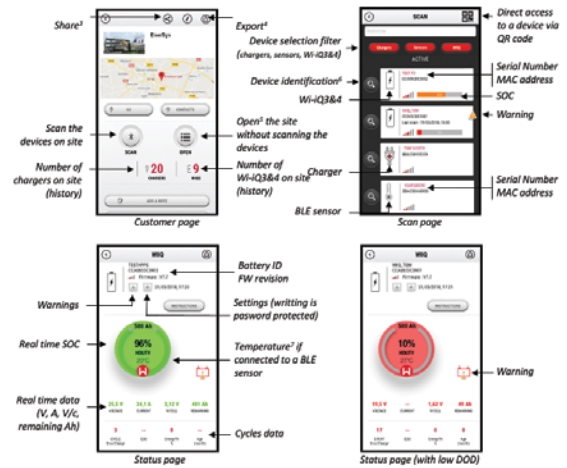

- Notes: (3) The "Share" button allows to share the site data with another user (through his e-mail address). By default, a customer site is only visible by its owner (who created it). (4) The "Export" button allows to export data in a .xrp file format which can be imported in the Wi-iQ Report software for deeper analysis. A web link to download the file is provided or sent to any user e-mail address. (5) The "Open" button allows to access to the list of devices already recorded in the customer site in Off-line mode. (6) The "Identification" button allows to visually identify the selected device through the identification sequence of its LEDs. (7) As long as the Wi-iQ4 is connected to the App, there is no communication with the BLE sensor (i.e. temperature data is not refreshed).

- 5.5.4** Refer to 5.4 "Configuring Wi-iQ4 Device within Wi-iQ Reporting Suite" to configure the battery parameters in the Wi-iQ4 device settings page of the app. The info required is the same (ie battery s/n, customer info, battery technology, battery capacity, number of cells, etc).

Figure 16: E Connect™ Mobile App Available Menu Options

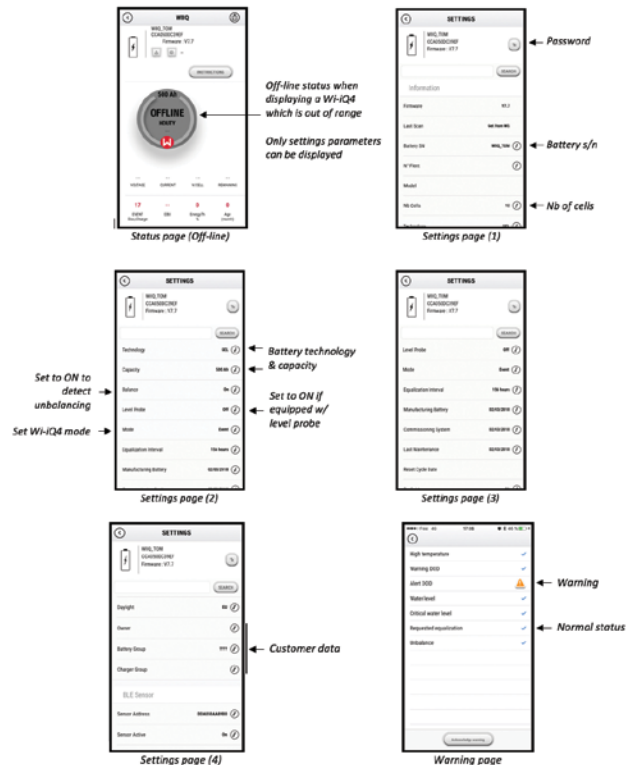

Multiple graphs are available (SOC, temperature, Ah...) with various period filters (day, week, year).

5. COMMUNICATION (CONTINUED)

5.6 Truck iQ™ smart battery dashboard

- 5.6.1** The Truck iQ™ smart battery dashboard is one of the latest “iQ” devices from EnerSys®.
- 5.6.2** The device consists of a display powered by the battery via the truck cables. It reads in real time and wirelessly data from the Wi-iQ4 device, displaying alerts, alarms, SOC and other useful parameters to optimize the operation of the battery.

Figure 17: Wi-iQ4 Device Communicates with Truck iQ Smart Battery Dashboard to Display Critical Battery Information



- 5.6.3** Pairing Truck iQ dashboard with Wi-iQ4 device
- 5.6.4** The Truck iQ dashboard can be paired with the Wi-iQ4 device either manually or automatically.
 - 5.6.4.1** Manual Procedure

Figure 18: Wi-iQ4 Device and Truck iQ Dashboard Pairing Instructions

Setting -> I/O -> Pairing -> Disable Auto pairing.

Select the appropriate Wi-iQ4 device by clicking on the BLE (Bluetooth) icon.

NB: The Wi-iQ4 device is normally equal to the battery name.

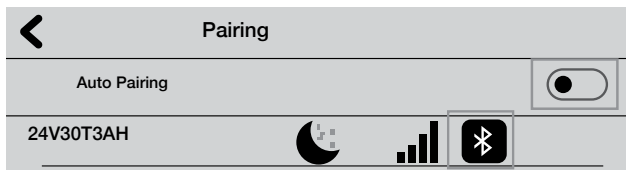

5.7 CAN (Controlled Area Network) Communication

- 5.7.1** EnerSys® allows integration via CAN supported protocols interfacing with the following:
 - 5.7.1.1** Trucks using OEM's proprietary CAN protocol implemented in the Wi-iQ4 device firmware.
 - 5.7.1.2** AGVs (Automated Guided Vehicle) using EnerSys proprietary CAN protocol (CANOpen Cia 418 or J1939).
 - 5.7.1.3** List of parameters communicated via CAN to trucks as specified by OEMs proprietary protocol, but not limited to:
 - 5.7.1.3.1** USOC (Usable State of Charge)
 - 5.7.1.3.2** DC Bus Voltage
 - 5.7.1.3.3** DC Bus Current
 - 5.7.1.3.4** System temperature (battery temperature)
 - 5.7.1.3.5** Lift Lock-out trigger
 - 5.7.1.3.6** Limited Operation trigger
 - 5.7.1.4** For more details, please refer to CAN Interface Specification provided with the truck's user manual for each specific OEM.

- 5.7.1.5** Parameter communicated via CAN to AGV as specified by EnerSys proprietary CAN protocol, but not limited to:
 - 5.7.1.5.1** USOC (Usable State of Charge)
 - 5.7.1.5.2** DC Bus Voltage
 - 5.7.1.5.3** DC Bus Current
 - 5.7.1.5.4** System temperature (battery temperature)
- 5.7.1.6** For more details, please refer to EnerSys Global: CAN Open and CAN J1939 specification for battery controller document **ENER-CO-002** and document **EnerSys_J1939**.

6. SERVICE AND TROUBLESHOOTING

6.1 Displayed error messages

Figure 19: Wi-iQ4 Device LEDs

- 6.1.1** Check the LED indicators on the device. Fast blinking every five



seconds of all LEDs indicates successful setup and normal operation. Refer to the table below for troubleshooting other indicators:

Table 9: Diagnostic Table

LED Indicator	LCD Display	Meaning
Fast blink every 5 seconds		Installation OK
Flashing Blue		Balance installed or programmed incorrectly
	No temp sensor	Level probe not inserted or incorrectly programmed
	No current sensor	Hall effect not connected or not reading
Flashing Red	Temperature	Possible bad thermal probe (if persistent)

- 6.1.2** Connect to the device with the E Connect™ mobile app
 - 6.1.2.1** If it won't connect, verify no other devices are connected, such as another App or Truck iQ™ dashboard. It can only connect to one device at a time.
 - 6.1.2.2** Try to connect with a computer and Wi-iQ® Report
 - 6.1.2.3** If it doesn't connect to either device. Move the Wi-iQ4 device to another area, preferably outdoors.
 - 6.1.2.3.1** If it connects in another location, the problem is radio magnetic interference.
 - 6.1.2.3.2** If it does not connect, replace the Wi-iQ4 device
- 6.1.3** Perform the following quality checks to confirm proper installation. Compare values displayed on the LCD with variables measured from the battery (i.e., voltage, temperature, etc.).
 - 6.1.3.1** Select the “MEASURES” button to read Wi-iQ4 device real-time data
 - 6.1.3.1.1** Measure voltage from the positive terminal of the battery to the VBAL/CEL gray wire with a calibrated voltmeter. Divide the reading by the number of cells between the positive terminal and the balance wire. Compare this value to the “VBAL/CEL” reading and confirm is within a tolerance of (+/- .02 VDC). Deviation from this value indicates the wrong number of cells was input into the “Cells Bal” field, or the Balance Wire is in the wrong location.

6. SERVICE AND TROUBLESHOOTING (CONTINUED)

- 6.1.3.1.2** Measure the voltage between the positive and negative battery post with a calibrated voltmeter. Divide the number of cells in the battery and confirm this value is within a tolerance of (+/- .03 VDC) of the value in "VBAT/CEL". Deviation from this value may indicate a bad electrical connection. Clean and grease the battery post and terminal lug.
- 6.1.3.1.3** Measure the temperature near the Temperature Probe on the battery. Verify the value in the "Temp" field is near the as read value. Large deviations indicate a bad thermal sensor.
- 6.1.3.1.4** If possible, operate the equipment or charge the battery. Measure the current with a calibrated clamp-on ammeter and confirm the value is within (+/- 2%) tolerance of the value in "CURRENT". Deviation from this value indicates a bad Hall Effect Sensor.
 - 6.1.3.1.4.1** Also verify the current is in the proper direction, (-) for discharger and (+) for charge. Deviation from this indicates the Hall Effect Sensor was installed backwards.
- 6.1.3.1.5** Verify the electrolyte indicates properly. If the probe is covered and the indication in "Measures" is not green, verify the balance wire is on the negative post of the same cell the electrolyte probe is installed.
 - 6.1.3.1.5.1** If installed correctly, inspect the probe for corrosion. Replace probe if damaged.

6.2 For service, contact your EnerSys sales representative or visit www.enersys.com.



EnerSys World Headquarters
2366 Bernville Road
Reading, PA 19605, USA
Tel: +1-610-208-1991 /
+1-800-538-3627

EnerSys EMEA
EH Europe GmbH
Baarerstrasse 18
6300 Zug, Switzerland

EnerSys Asia
152 Beach Road
#11-08 Gateway East Building
Singapore 189721
Tel: +65 6416 4800