



UPE Series Enclosures



Storm Hood and Filter Kit Field Installation Guide

UPE-4 and UPE-8 Enclosures

Effective: October, 2002

Power **Alpha Technologies.** Protecting The Power in Communications.

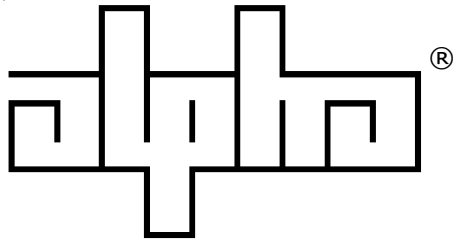

UPE-4, UPE-8
Storm Hood and Filter Kit
Field Installation Guide
745-179-C0-001, Rev A
Effective Date: October, 2002
© Alpha Technologies, Inc.



NOTE: Photographs contained in this manual are for illustrative purposes only. These photographs may not exactly match your installation.



NOTE: Review the drawings and illustrations contained in this manual before proceeding. If there are questions regarding the safe operation of this powering system, please contact Alpha Technologies or your nearest Alpha representative.

Contacting Alpha Technologies:

For general **product information and customer service**

1-800-863-3930

(7:00 AM to 5:00 PM Pacific Time)

For complete **technical support**

1-800-863-3364

(7:00 AM to 5:00 PM Pacific Time, or 24/7 emergency support)

Table of Contents

Section One, Introduction

1.1 Safety Information	5
1.2 Parts List.....	6
1.3 Required Tools	6

Section Two, Installation

2.1 Weather Stripping Installation	7
2.2 Front Door Cover Installation	8
2.3 Side and Rear Cover Installation	9
2.4 Louver Filter Installation	10
2.5 Completed Installation	11

List of Figures

Fig. 1 Applicable Enclosure Style.....	6
Fig. 2 Weather Stripping placement	7
Fig. 3 Door Cover Placement	8
Fig. 4 Side and Rear Cover Placement	9
Fig. 5 Louver Filter Placement	10
Fig. 6 Completed Installation	11

1. Introduction

1.1 Safety Information

- **SAVE THESE INSTRUCTIONS:** This manual contains important installation instructions, and should be saved for future reference.

This safety symbol will be found throughout this manual, carefully read all information boxes and abide by the instructions:

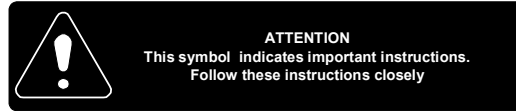

The following levels of warning will be used with the above symbols:

ATTENTION: Information or Instructions that must be followed closely

DANGER: You **WILL** be **KILLED** or **SERIOUSLY INJURED** if instructions are not followed closely

WARNING: You **CAN** be **KILLED** or **SERIOUSLY INJURED** if instructions are not followed closely

CAUTION: You can be **INJURED**, or equipment can be **DAMAGED** if instructions are not followed closely

1. Introduction

1.2 Parts List

Each kit contains: (kit items are labeled 1 through 9)

- 3 Storm hood vent covers (items 4, 8, and 9)
- 2 Weather stripping, 3 pcs. (item 6)
- 8 Filter pads, 8 pcs. (items 1, 2, 3, and 7)
- 16 Rivets, 14 pcs.

1.3 Required Tools

1/2" drive hand drill

9/64" (#28) drill bit

Rivet gun with 1/8" nose piece

Heavy duty scissors or utility knife

Tape measure

Vacuum to remove metal shavings from interior of cabinet.

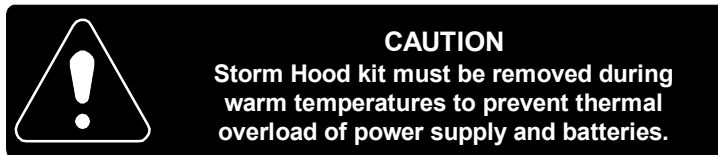

This storm hood and filter kit is designed for UPE Series enclosures manufactured after mid-2002. If the enclosure has louvers on the front door, this kit applies.

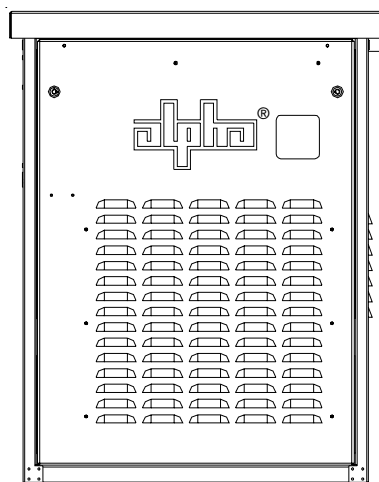

Correct Enclosure

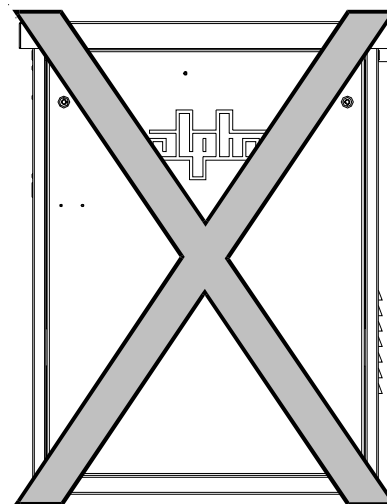

Wrong Enclosure

Fig. 1 Applicable Enclosure Style

2.1 Weather Stripping Installation Procedure

1. Cut the weather stripping, item 6, to length according to the chart below:

Enclosure Model	Bottom Strip (a)	Side Strips (b)
UPE-4	30 Inches	19 Inches
UPE-8	30 Inches	31.75 Inches

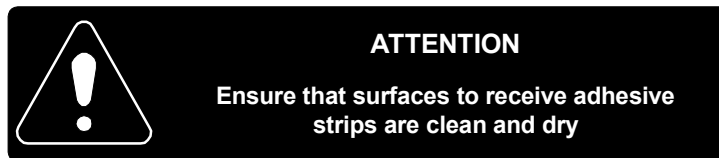

2. Remove the front door of the enclosure.
3. Remove the protective paper from the adhesive strips, and press the weather stripping into place, making sure the ends meet at the corners and butt against the existing weather strip at the sides. Some trimming may be necessary.

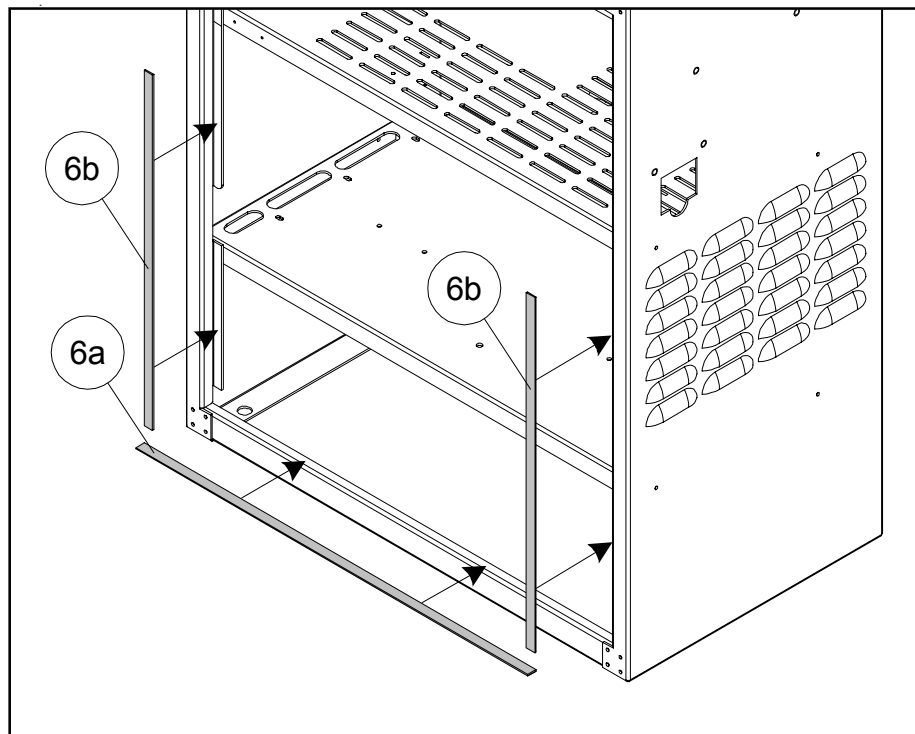

Fig. 2 Weather Stripping Placement

2. Installation

2.2 Front Door Cover Installation Procedure

1. Drill six 9/64" holes at the center punches on both sides of the louvers.
2. Remove the protective paper from the adhesive strips on item 3 (2 pcs), and place on the top and bottom of the storm cover, item 4.
3. Using the rivets provided with the kit, attach the storm cover to the enclosure's front door (see inset below).
4. Leave the door off for the remainder of the installation.

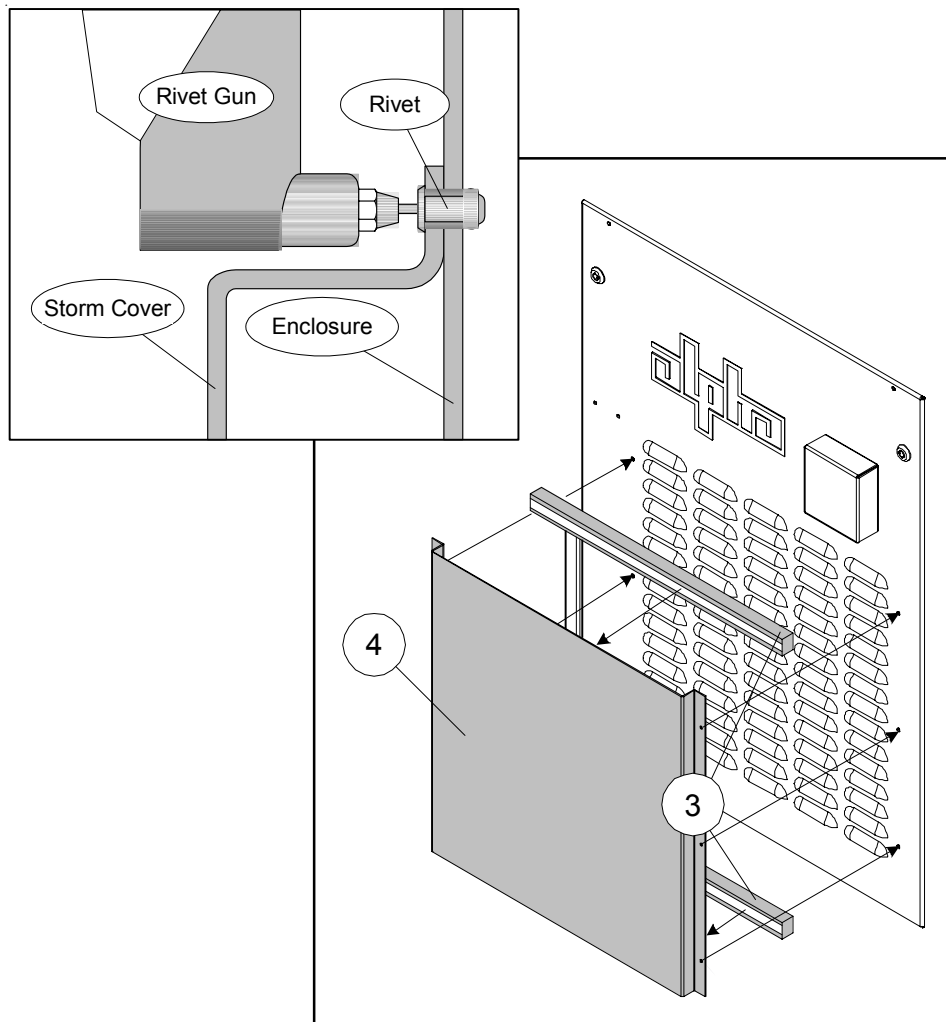
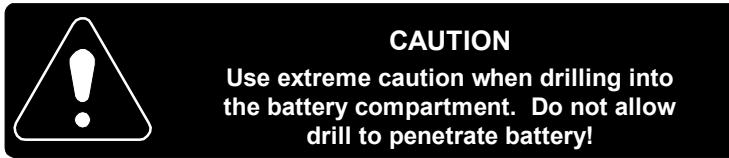

Fig. 3 Door Cover Placement

2.3 Side / Rear Cover Installation Procedure



1. Set BATTERY BREAKER on the power supply to OFF. Set the AC SERVICE BREAKER to the OFF position.
2. Move batteries as far away as possible from the area where drilling is taking place. If unsure, remove battery pack from enclosure.
3. Drill eight 9/64" holes at the center punches on the side and back of the enclosure, directly above and below the louvers.
4. Remove the protective paper from the adhesive strips on item 1 (4 pcs), and place on either side of both storm covers, item 8 and 9.
5. Using the rivets provided with the kit, attach the storm covers to the side and back of the enclosure.
6. Remove any shavings from the interior of the enclosure.

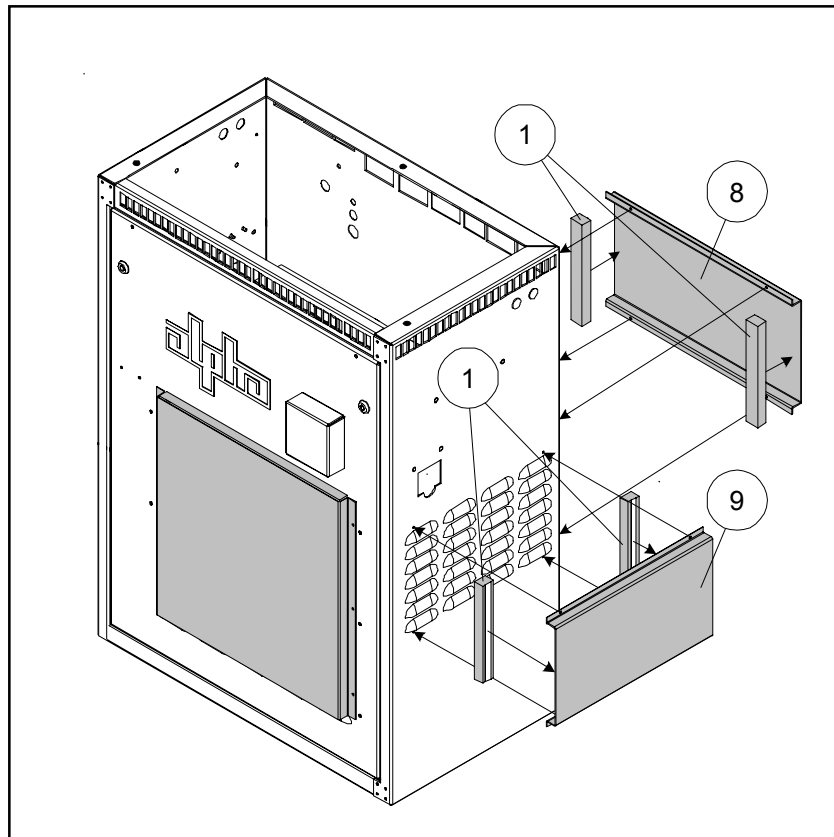
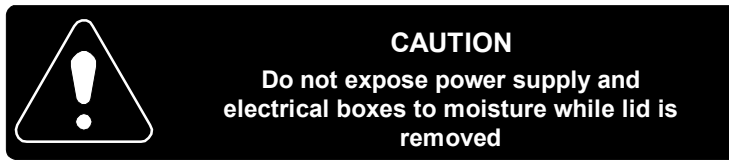

Fig. 4 Side and Rear Cover Placement

2. Installation

2.4 Louver Filter Installation Procedure



1. Unlock and remove the front door, if installed.
2. From the inside, remove the three wing-nuts holding the lid onto the enclosure, remove the lid and set aside.
3. Remove the protective paper from the adhesive strips on item 2, and press into place on the back inside wall of the enclosure. Ensure all louvers are covered.
4. Fold item 7 so that the right side (as seen from the front of the enclosure) is 12.1 inches long, and the left side is 6.5 inches long.
5. Remove the protective paper from the adhesive strip on item 7, and press into place on the front inside wall of the enclosure. Ensure all louvers on the front and sides are covered.
6. Replace the lid, reinstall and tighten the wing-nuts.
7. Replace and lock the front door.

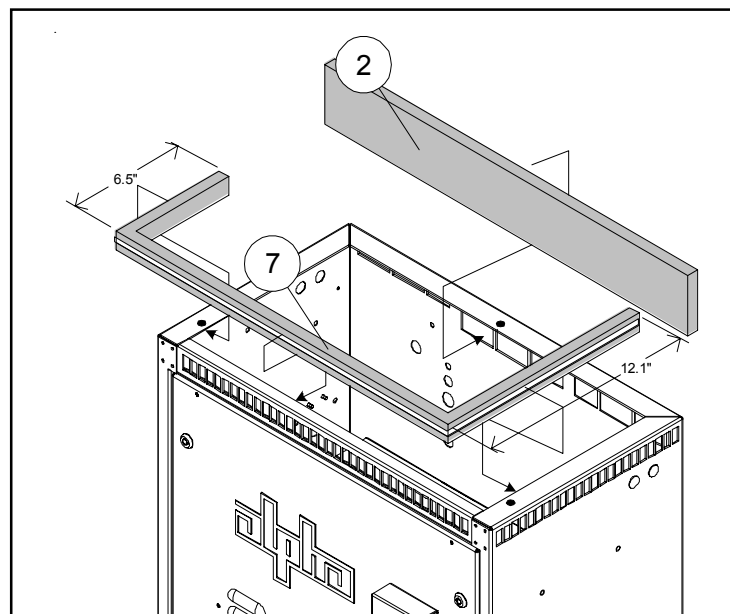

Fig. 5 Louver Filter Placement

2. Installation

2.5 Completed Installation

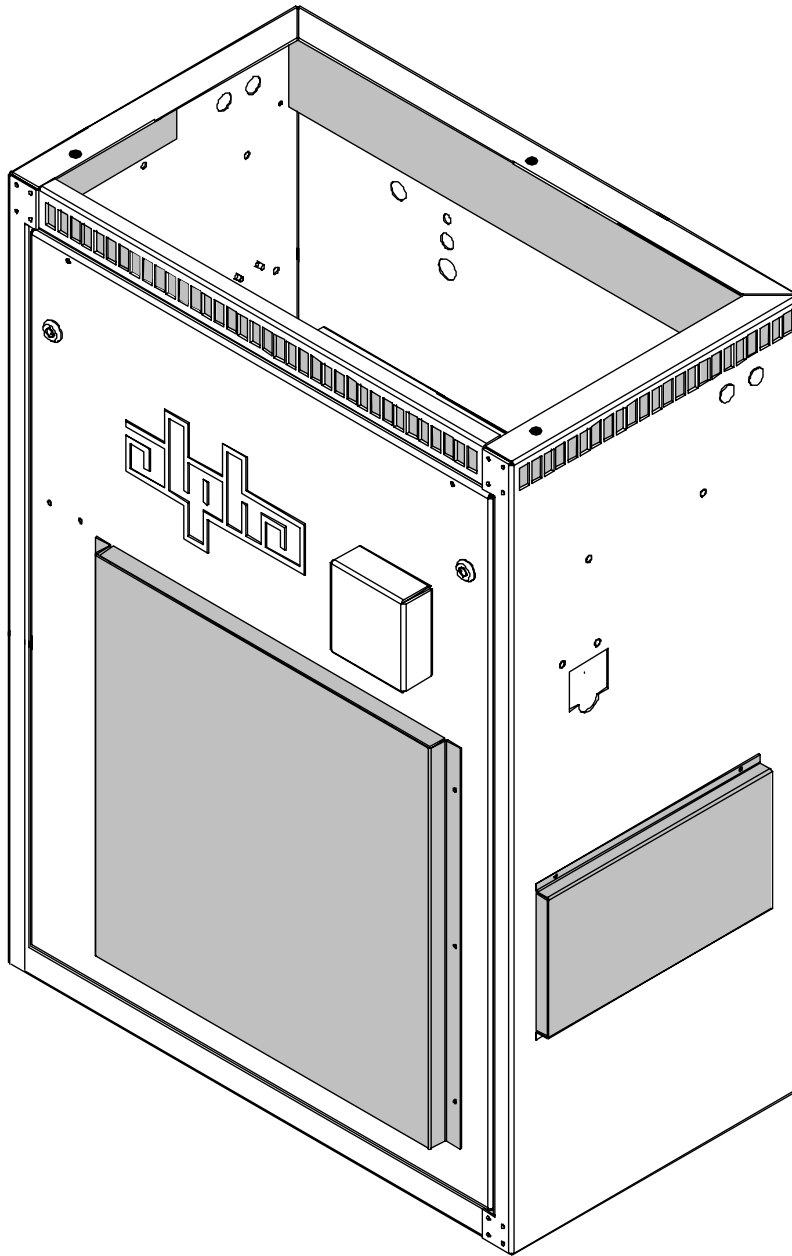

Fig. 6 Completed Installation (lid removed to show detail)

Power

www.alpha.com Protecting The Power in Communications.

Corporate

Alpha Technologies
3767 Alpha Way
Bellingham, WA 98226
USA
Tel: (360) 647-2360
Fax: (360) 671-4936
Web: www.alpha.com

Alpha Technologies Ltd.
4084 McConnell Court
Burnaby, BC, V5A 3N7
CANADA
Tel: (604) 430-1476
Fax: (604) 430-8908

Alpha Technologies
Europe Ltd.
Cartel Business Estate
Edinburgh Way
Harlow, Essex CM20 2TT
UNITED KINGDOM
Tel: +44-1279-422110
Fax: +44-1279-423355

Alpha Technologies
Hansastrasse 8
D-91126 Schwabach
GERMANY
Tel: +49-9122-79889-0
Fax: +49-9122-79889-21

Alphatec
339 St. Andrews Street
Suite 101
Andrea Chambers
Limassol, Cyprus
CYPRUS
Tel: +357-25-375675
Fax: +357-25-359595

Alpha Technologies
Unit R5-R7 Regents Park Estate
Corner Park Rd and Prince's Rd East
Regents Park, NSW 2143
AUSTRALIA
Tel: +61-2-9722-3320
Fax: +61-2-9722-3321